

AIR ANGLE DIE GRINDER

Specifications

Collet Size. 1/4"
 Free Speed. 20,000RPM
 Air. 4CFM@90PSI

Air Inlet 1/4"PT
 Weight. 0.50kg
 Air Outlet. Rear Exhaust

Parts List

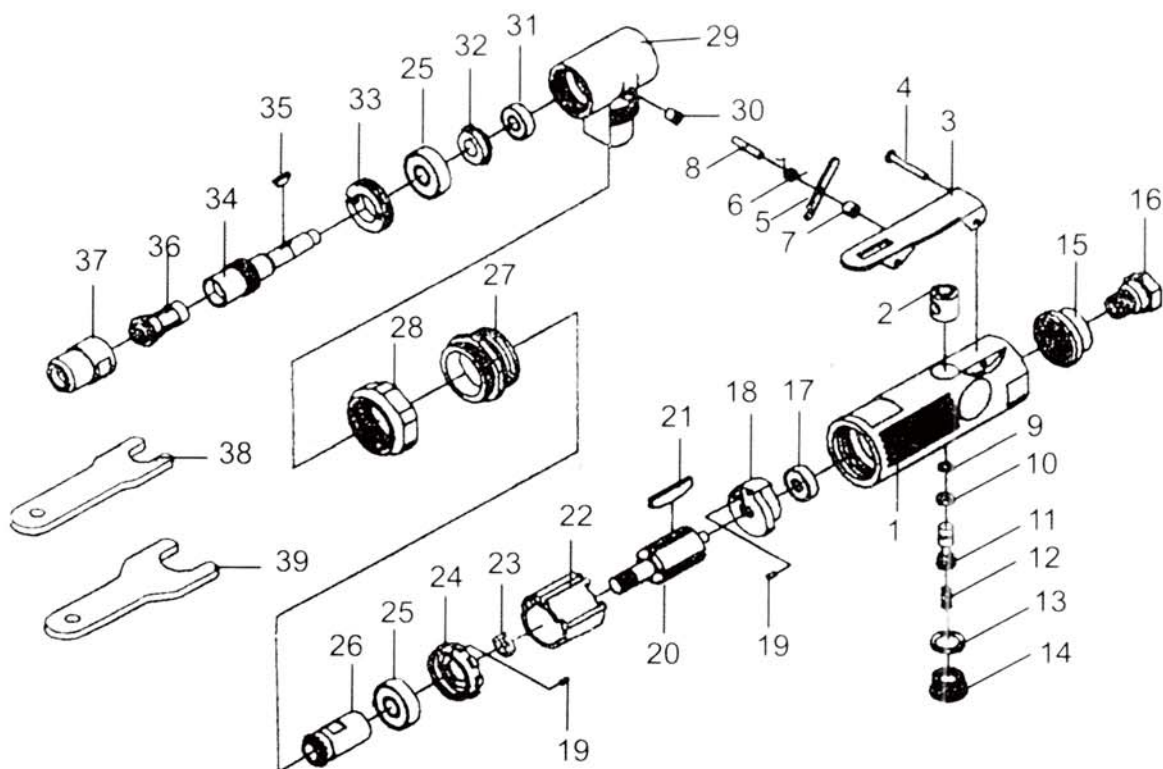

Ref.	Description	Q'TY
1	Housing	1
2	Valve Bushing	1
3	Trigger	1
4	Trigger Pin	1
5	Safety Lever	1
6	Spring	1
7	Washer	1
8	Pin	1
9	O-ring	2
10	O-ring	2
11	Valve Stem	1
12	Spring	1
13	O-ring	1
14	Valve Plug	1
15	Muffler	1
16	Air Inlet	1
17	Bearing	1
18	Rear Plate	1
19	Pin	1
20	Rotor	1

Ref.	Description	Q'TY
21	Rotor Blade	4
22	Cylinder	1
23	Rotor Washer	2
24	Front Plate	1
25	Bearing	1
26	Umbrella Gear (Active)	1
27	Screw	1
28	Nut	1
29	90° Elbow	1
30	Press - in Oil Valve	1
31	Bearing	1
32	Umbrella Gear (Driven)	1
33	Slot Nut	1
34	Transmission Shaft	1
35	Semicircular Key	1
36	1/4" Collet	1
37	Collet Nut	1
38	Wrench	1
39	Wrench	1