

# 318-151(152,153) AIR SCREWDRIVER SPARE PARTS

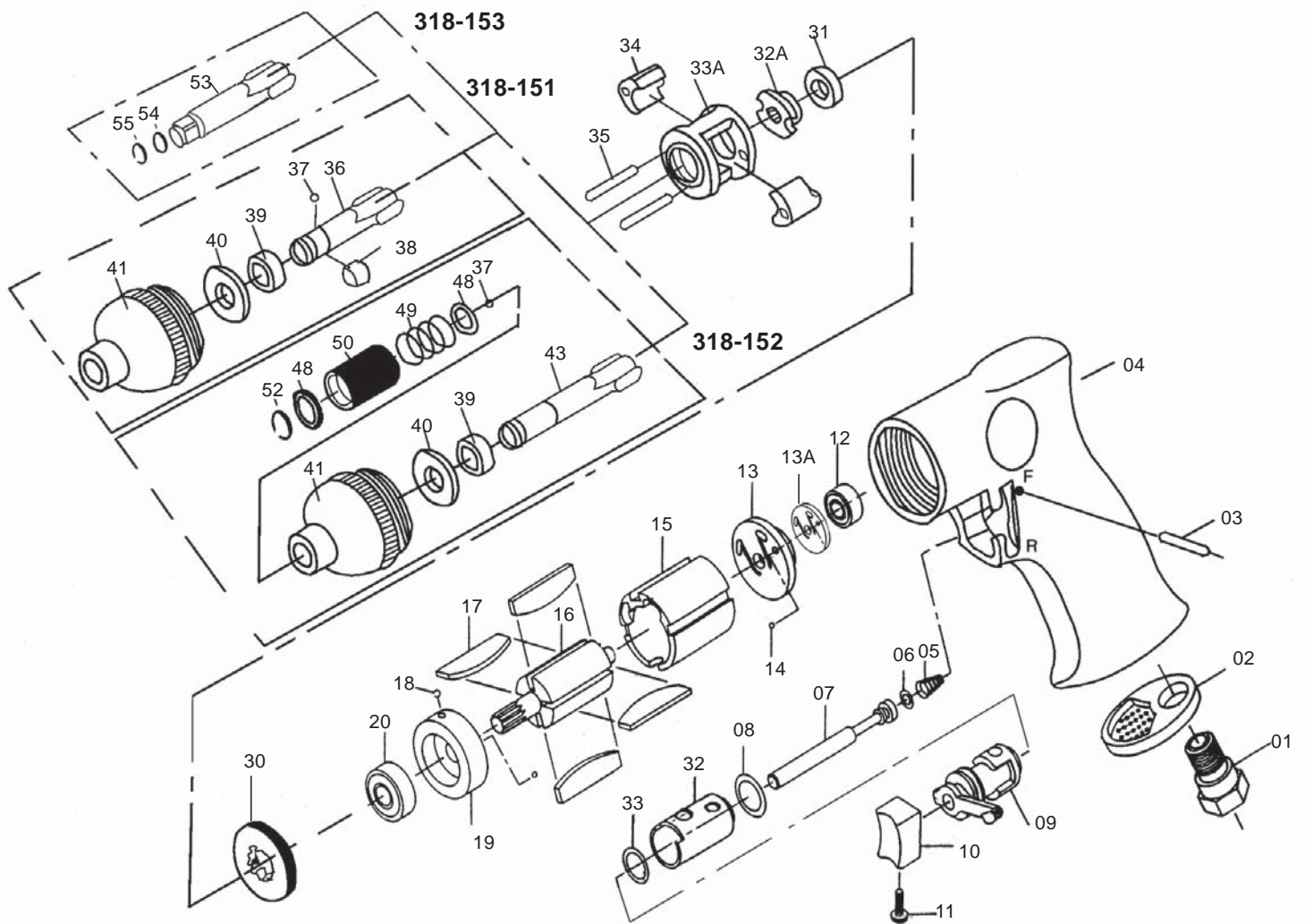

No.	Model No.	Description	Qty
01	318-131-01	Air Inlet	1
02	318-131-02	Exhaust Sleeve	1
03	318-131-03	Spring Pin	1
04	318-131-04	Housing	1
05	318-131-05	Spring	1
06	318-131-06	O-Ring	1
07	318-131-07	Valve Stem	1
08	318-131-08	O-Ring	1
09	318-131-09	Reverse Lever	1
10	318-131-10	Trigger	1
11	318-131-11	Screw	1
12	318-131-12	Bearing	1
13	318-131-13	Rear Plate	1
13A	318-131-13A	Washer	1
14	318-131-14	Steel Ball	1
15	318-131-15	Cylinder	1
16	318-131-16	Rotor	1
17	318-131-17	Rotor Blade	4
18	318-311-18	Steel Ball	1
19	318-131-19	Front Plate	1
20	318-131-20	Bearing	1

No	Parts No.	Description	Qty
30	311-111-30	Nut	1
31	311-111-31	Washer	1
32	318-131-32	Bushing	1
32A	311-111-32A	Cam	1
33	318-131-33	O-Ring	1
33A	311-111-33A	Hammer Housing	3
34	311-111-34	Hammer	2
35	311-111-35	Pin	2
36	311-111-36	Anvil	1
37	311-111-37	Steel Ball	1
38	311-111-38	Steel Ball Collar	1
39	311-111-39	Collar	1
40	311-111-40	Washer	1
41	311-111-41	Housing Cap	1
43	311-121-43	Anvil	1
48	311-121-48	Washer	2
49	311-121-49	Spring	1
50	311-121-50	Spring Seat	1
52	311-121-52	Circllet	1
53	311-113-36	Anvil	1
54	311-113-37	O-Ring	1
55	311-113-38	Circllet	1

# 1/4" AIR SCREWDRIVER INSTRUCTION

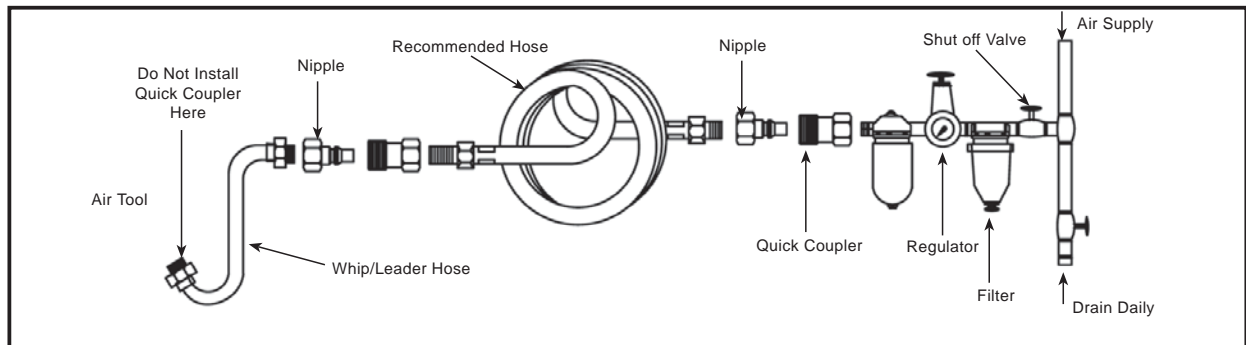

Figure 1

## SPECIFICATION

Collet Size: 1/4"

Free Speed: 10000 RPM

Max.Torque: 20-60 FT-LB

Avg.Consumption: 6 CFM

Recommended Hose Bore Size: 3/8"

Air Pressure: 90 PSI

Air Inlet: 1/4"

## AIR SUPPLY

An air compressor of at least one horsepower with 4 CFM delivery at 90 psi(6.2 bar) with an air tank of a minimum 12-gallon capacity is required.

Couplings, as shown in the illustration above, may be used. Do not connect couplers directly to the air inlet. They increase the overall bulk of the tool, put an unnecessary strain on the tool inlet threads, and deteriorate rapidly due to vibration.

Water in the air line will cause damage to the tool. Drain the air tank daily. Clean the air inlet screen on at least a weekly schedule. The recommended hook-up procedure can be viewed in Figure 1.

Please put lubricating oil on the machine at a certain period for long life.

## SAFETY RULES

1. Always wear approved eye protection. Be sure to use a dust mask when operation creates dust.
2. Disconnect tool before performing service, changing accessories and when not in use.
3. Always use tool a safe distance from other people in work area.
4. Secure work with clamps or vise so both hands are free to operate tool.  
Keep proper footing and balance at all times.
5. Do not wear loose or ill-fitting clothing, remove watches and rings.
6. Keep tool away from body when it is running.
7. Never use quick change couplings attached at tool. They add weight and could fail due to vibration. Instead, add a hose whip and connect coupling between air supply and hose whip.
8. Keep the surface of body clean. Please hold the machine tightly while work.