

F323-48(TWIN HAMMER) IMPACT WRENCH

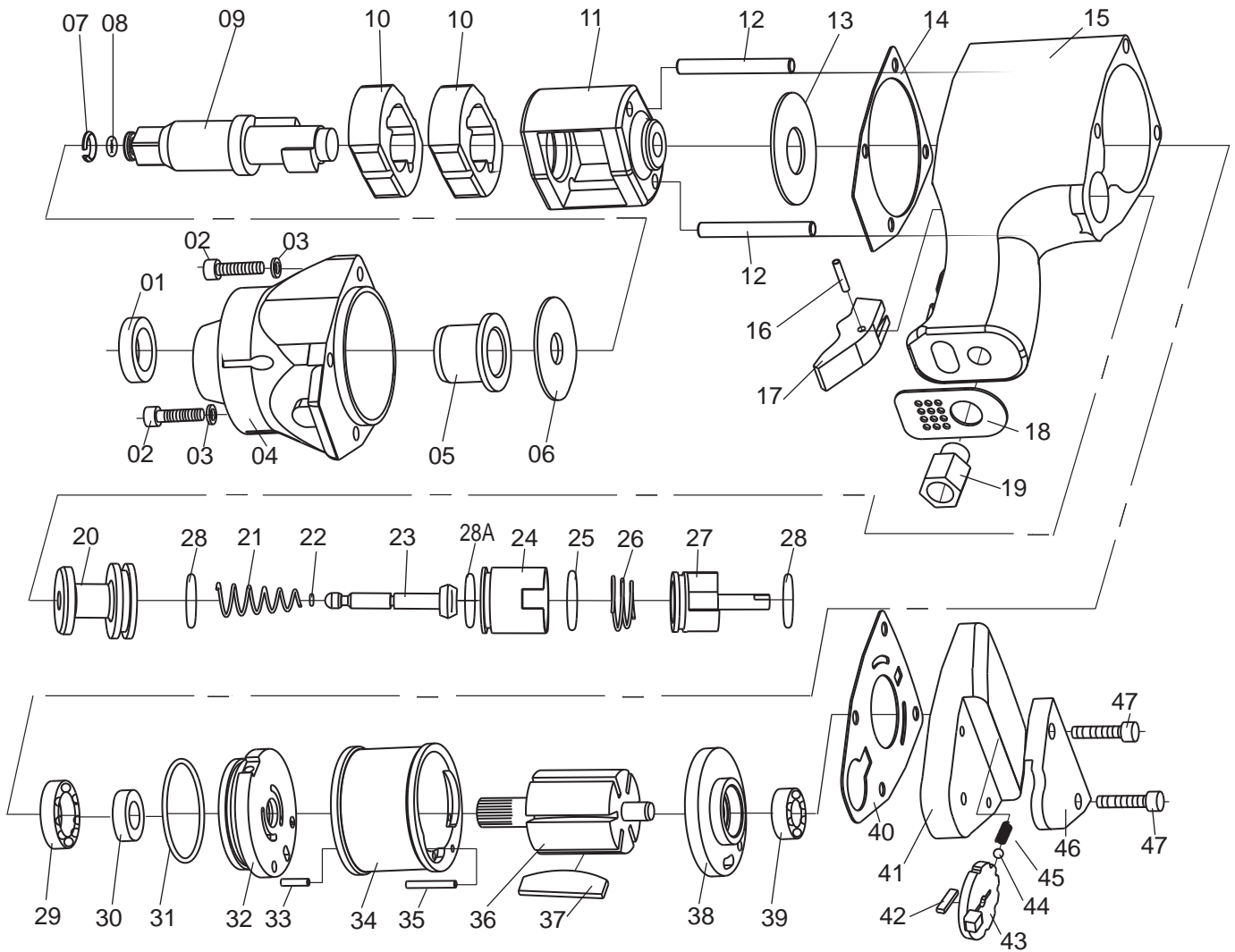

NO.	PART NO.	DESCRIPTION	Q'TY
01	F323-48-60	Oil Seal	1
02	F323-48-02	Hex. Bolt	6
03	F323-48-03	Spring Washer	8
04	F323-48-04	Hammer Cas	1
05	F323-48-08	Bushing	1
06	F323-48-24	Steel Spacer	1
07	F312-248-41	Spring	1
08	F312-248-42	O Ring	1
09	F323-48-26	Anvil	1
10	F323-48-28	Hammer Dog	2
11	F323-48-31	Hammer Cage	1
12	F323-48-31.1	Hammer Pin	2
13	F323-48-24.1	Steel washer	1
14	F323-48-59	Paper Washer	1
15	F323-48-07	Housing	1
16	F320-24-36	Spring Pin	1
17	F323-48-19	Trigger	1
18	F323-48-06	Steel Silencer	1
19	F313-329-01	Air Inlet	1
20	F323-48-49.1	Brass Bushing	1
21	F323-48-58	Spring	1
22	F323-48-50	O Ring	1
23	F323-48-49	Inlet Valve Stem	1
24	F323-48-52	Inlet Cage	1

NO.	PART NO.	DESCRIPTION	Q'TY
25	F323-48-53	O Ring	2
26	F323-48-61	Spring	1
27	F323-48-54	Reverse Valve	1
28	F323-48-55	O Ring	1
28A	F323-48-49.5	O Ring	1
29	F323-48-34	Bearing	1
30	F323-48-35	Oil Seal	1
31	F323-48-36	O Ring	1
32	F323-48-47	Front End Plate	1
33	F312-248-30	Spring Pin	1
34	F323-48-37	Cylinder	1
35	F312-248-23	Spring Pin	1
36	F323-48-33	Rotor	1
37	F323-48-32	Rotor Blade	6
38	F323-48-39	Rear End Plate	1
39	F323-48-40	Bearing	1
40	F323-48-41	Paper Spacer	1
41	F323-48-45	Rear Cover	1
42	F323-48-57	Directional Slice	1
43	F323-48-56	Reverse Lever	1
44	F323-48-12	Steel Ball	1
45	F323-48-13	Spring	1
46	F323-48-45.1	Adj. Rear Cover	1
47	F323-48-02.1	Hex. Bolt	2